

5-BURNER GAS GRILL WITH SIDE BURNER

PARRILLA DE GAS DE 5 QUEMADORES CON QUEMADOR LATERAL

BARBECUE À GAZ À 5 BRÛLEURS AVEC BRÛLEUR LATÉRAL

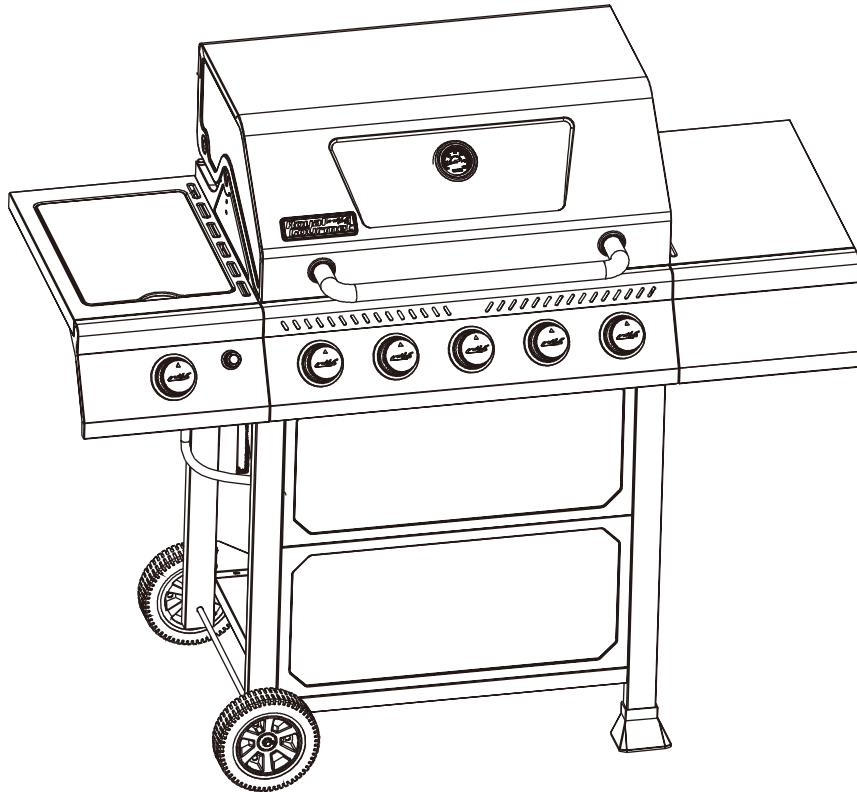

FOR YOUR SAFETY! | ¡PARA SU SEGURIDAD! | POUR VOTRE SÉCURITÉ!

Use outdoors only!
Read the instructions before
assembling and using the appliance.

¡Solo usa al aire libre!
Lea las instrucciones antes
de montar y utilizar el aparato.

Utilisez uniquement à l'extérieur!
Lisez les instructions avant
d'assembler et d'utiliser l'appareil.

CONTACT US FIRST! | ¡PÓNGASE EN CONTACTO CON NOSOTROS PRIMERO! | CONTACTEZ-NOUS D'ABORD!

If you have any questions that are
not addressed, please contact us first.

Si tiene alguna pregunta que no se
aborde en este Manual del Usuario,
póngase en contacto con nosotros primero.

Si vous avez des questions qui ne
sont pas traitées dans ce manuel de
l'utilisateur, contactez-nous d'abord.



Customer Service / Servicio al Cliente / Service de Clientèle



1-800-618-6798











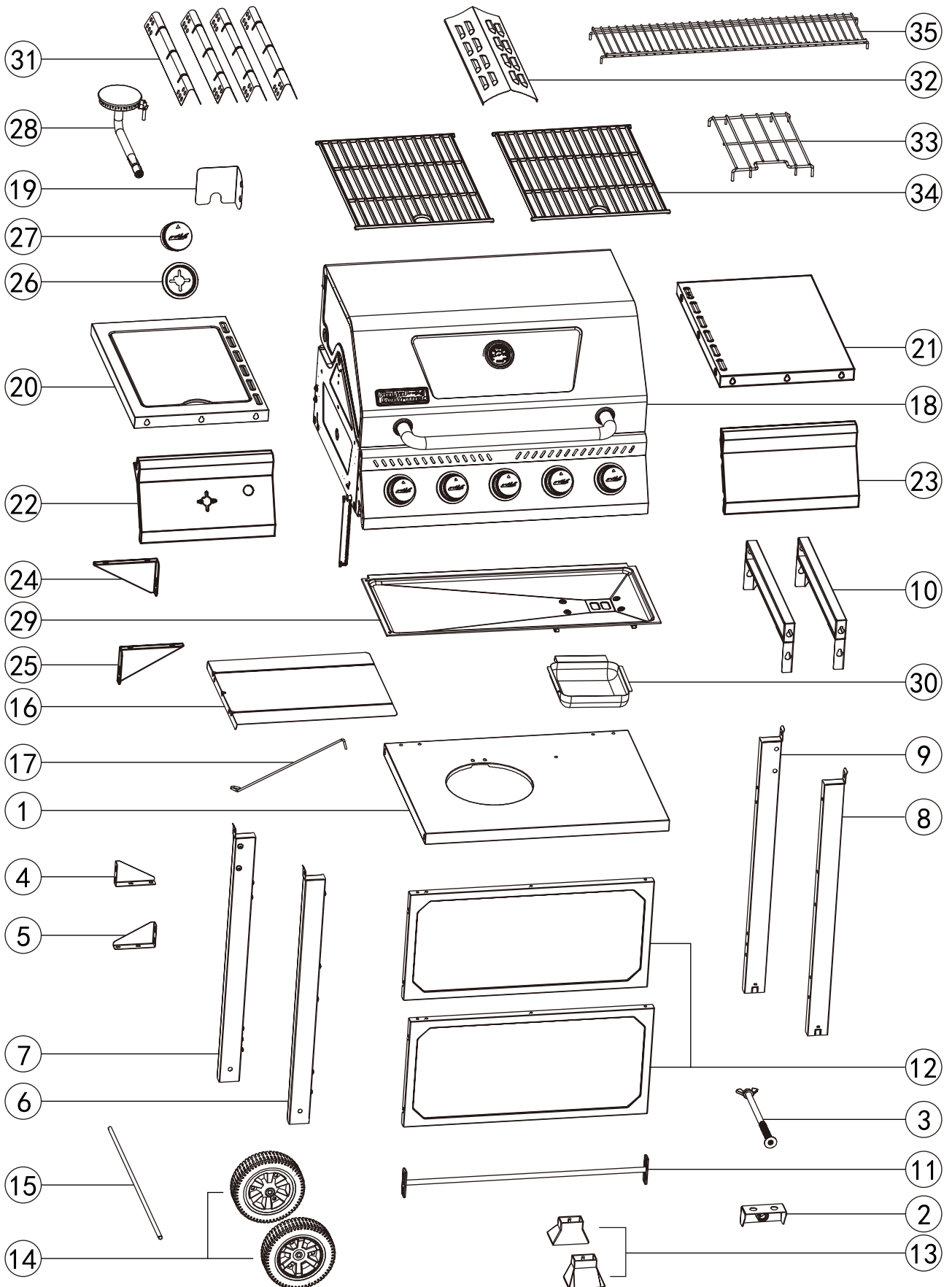









service@royalgourmetusa.com













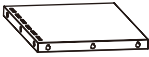



Learn more at / Obtener más información en / Pour en savoir plus:





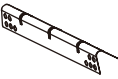



www.royalgourmetcorp.com





No.	#	QYT / CANT. / QTÉ	Description / Descripción / Description	Image / Imagen / Image
1	ACJ53DB4B	1	Bottom shelf Estante inferior Etagere inferieure	
2	AHQBGDZ	1	Screw bushing Buje del perno de fijación de la bombona Douille de vis	
3	DG01	1	LP cylinder screw Perno de fijación de la bombona Vis de bouteille de gaz	
4	ACJ53SJPL	1	Triangle support plate (L) Placa de soporte triangular (I) Plaque de support triangulaire (G)	
5	ACJ53SJPR	1	Triangle support plate (R) Placa de soporte triangular (D) Plaque de support triangulaire (D)	
6	AHCJ53TGLF	1	Left front leg Pata delantera izquierda Jambe avant gauche	
7	AHCJ53TGLB	1	Left back leg Pata trasera izquierda Jambe arrière gauche	
8	AHCJ53TGRF	1	Right front leg Pata delantera derecha Jambe avant droite	
9	AHCJ53TGRB	1	Right back leg Pata trasera derecha Jambe arrière droite	
10	AHCJ53CHL	2	Cart side beam Barra lateral del carro Barre latérale du chariot	
11	AHCJ53HL4B	1	Cart rear beam Barra trasera del carro Barre arrière du chariot	
12	ACJ53QDB4B	2	Cart board Panel de carro Panneau du chariot	
13	AJS001	2	Leg base Base de la pata Base de pied	
14	LZ300	2	Wheel Rueda Roue	
15	LZ004	1	Wheel axle Eje de las ruedas Axe de roue	
16	AQPGB	1	Thermal baffle Deflector térmico Panneau isolant	
17	AZX001	1	LP cylinder barrier bar Barra de seguridad para la bombona de gas Barre de barrière de bouteille de gaz	

No.	#	QYT / CANT. / QTÉ	Description / Descripción / Description	Image / Imagen / Image
18		1	Main body Cuerpo principal Corps principal	
19	ABLGRB	1	Side table thermal baffle Deflector térmico de mesa lateral Panneau isolant de table d'appoint	
20	ABLNMBSL+ ACTNBLSG	1	Side burner shelf Base del quemador lateral Etagère du bruleur d'appoint	
21	ACTNMBSL	1	Side table Mesa lateral Table d'appoint	
22	AHBLNZSJL	1	Side burner decoration board Panel decorativo del quemador lateral Panneau de décoration du bruleur d'appoint	
23	AHCTNZSJR	1	Side table decoration board Panel decorativo de la mesa lateral Panneau de décoration de la table d'appoint	
24	ACTNSZJL	1	Side burner support plate Placa de sujeción del quemador lateral Plaque de support du bruleur d'appoint	
25	ACTNSZJR	1	Side table support plate Placa de sujeción de la mesa lateral Plaque de support de table d'appoint	
26	XZ103 (W-20120007)	1	Knob base Base de mando de regulación de llama Base du bouton	
27	XN101RGC-BK	1	Knob Mando de regulación de llama Bouton	
28	ABLT001	1	Side burner Quemador lateral Bruleur d'appoint	
29	ALTJYP4B	1	Grease tray Bandeja de recogida de grasa Lèche-frite	
30	Z-DXL12047	1	Grease cup Depósito de recogida de grasa Bac à graisse	
31	ADB01	4	Flame tamer Regulador de llama Atténuateur de flamme	
32	AGDB01	1	Flame tamer (big) Regulador de llama (grande) Gros atténuateur de flamme	
33	AGJ001	1	Side burner grate Rejilla del quemador lateral Grille du bruleur d'appoint	
34	AKW001	2	Cooking grate Rejilla para asar Grille de cuisson	
35	ABW104-4B	1	Warming rack Rejilla para calentar Grille de réchauffement	

Key / Clave / Réf.	Description / Descripción / Description	QTY / CANT. / QTÉ	Image / Imagen / Image
A	M5x10	41	
B	M6x12	28	
C	M4x8	4	
D	M6x12	1	
E	Split pin Pasador partido Goupille fendue	2	
F	Pad Arandela Tampon	2	
G	Hose holder Anilla de fijación Support de tuyau	1	
H	Washer Arandela Rondelle	6	

TOOLS REQUIRED / HERRAMIENTAS REQUERIDAS / OUTILS REQUIS

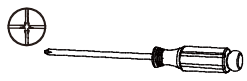
Description / Descripción / Description	Image / Imagen / Image
Phillips screwdriver Destornillador phillips Tournevis phillips	

Before beginning assembly, make sure all parts are present. If any parts are missing or damaged, do not attempt to assemble the products. Contact customer service for replacement parts via telephone or email.

- Tools needed (not included): Phillips screwdriver and wrench
- Approximate assembly time: 70 minutes
- Note: 1. The right and left sides of the grill are designed as if you are facing the front of the grill.
2. Model shown for illustration purpose only, specific please in kind prevail.

Antes de comenzar el montaje, asegúrese de que todas las piezas estén presentes. Si falta alguna pieza o está dañada, no intente ensamblar los productos. Póngase en contacto con el servicio de atención al cliente para obtener piezas de repuesto por teléfono o correo electrónico.

- Herramienta necesaria (no incluido): Destornillador phillips y llave
- Tiempo aproximado de ensamblaje: 70 minutos
- Nota: 1. Los lados derecho e izquierdo de la parrilla están diseñados como si estuvieras frente a la parte delantera de la parrilla.
2. El modelo que se muestra es sólo para fines ilustrativos, prevalecen los específicos en especie.

Avant de commencer l'assemblage, assurez-vous que toutes les pièces sont présentes. Si des pièces sont manquantes ou endommagées, n'essayez pas d'assembler les produits. Contactez le service de clientèle pour les pièces de rechange par téléphone ou par e-mail.

- Outils nécessaires (non inclus): Tournevis phillips et clé
- Temps nécessaire pour l'assemblage: 70 minutes
- Remarque: 1. les côtés droit et gauche du gril sont conçus comme si vous faisiez face à l'avant du gril.
2. le modèle est présenté à des fins d'illustration uniquement, spécifiques en nature prévalent.

1	B		×2
----------	---	---	----

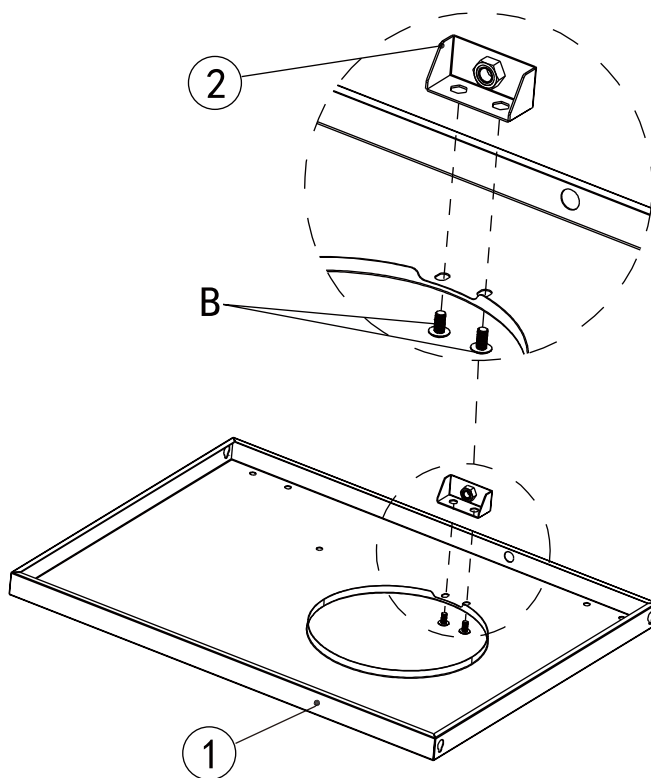

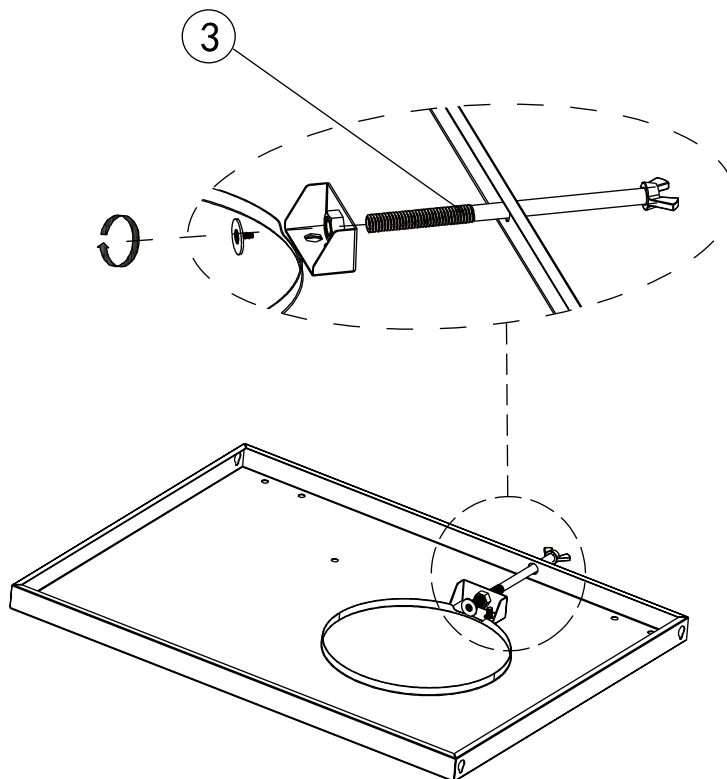

2

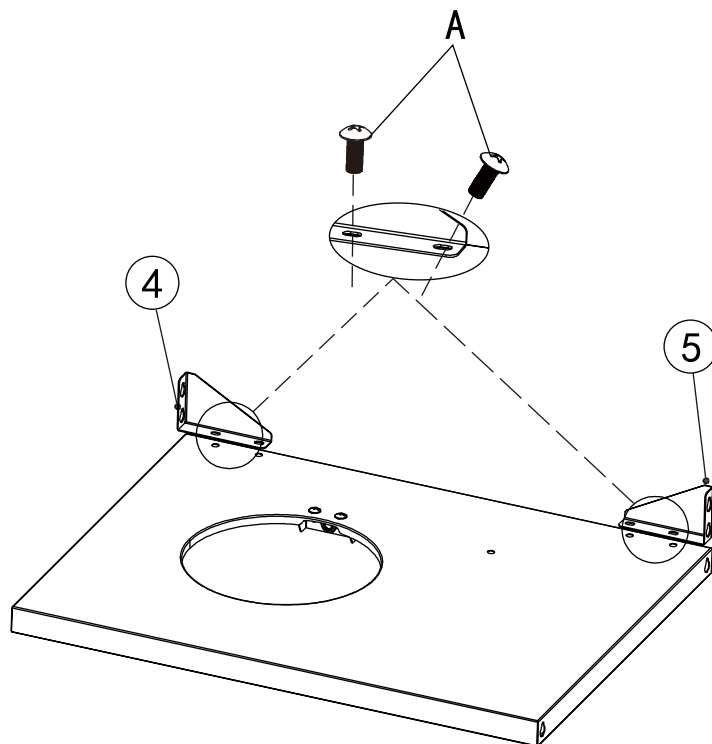

3	A		×4
---	---	---	----



4	A		×20
	B		×8

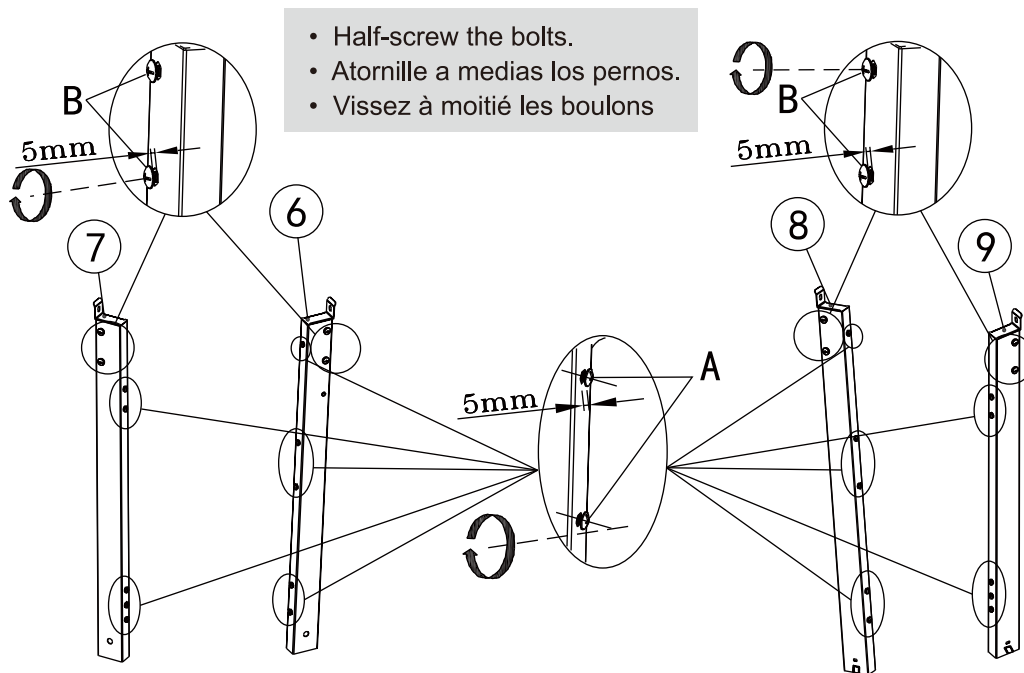

5

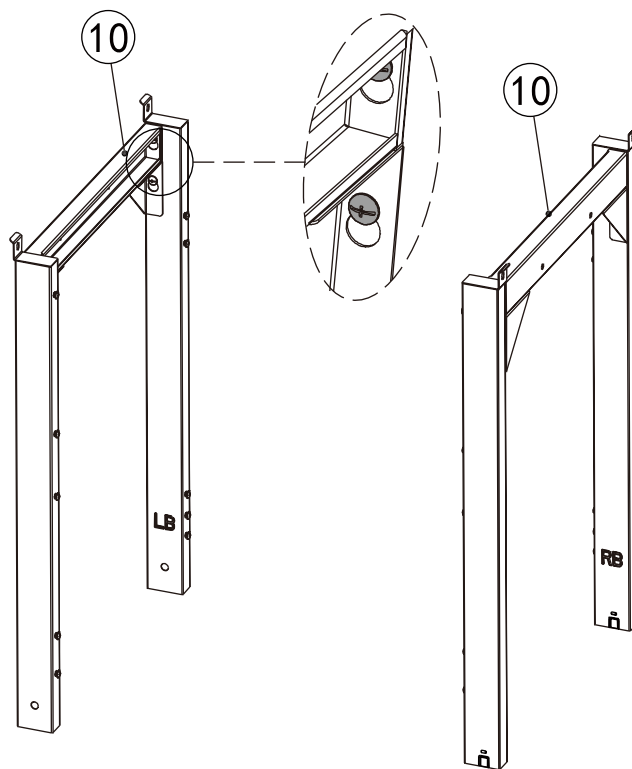

6

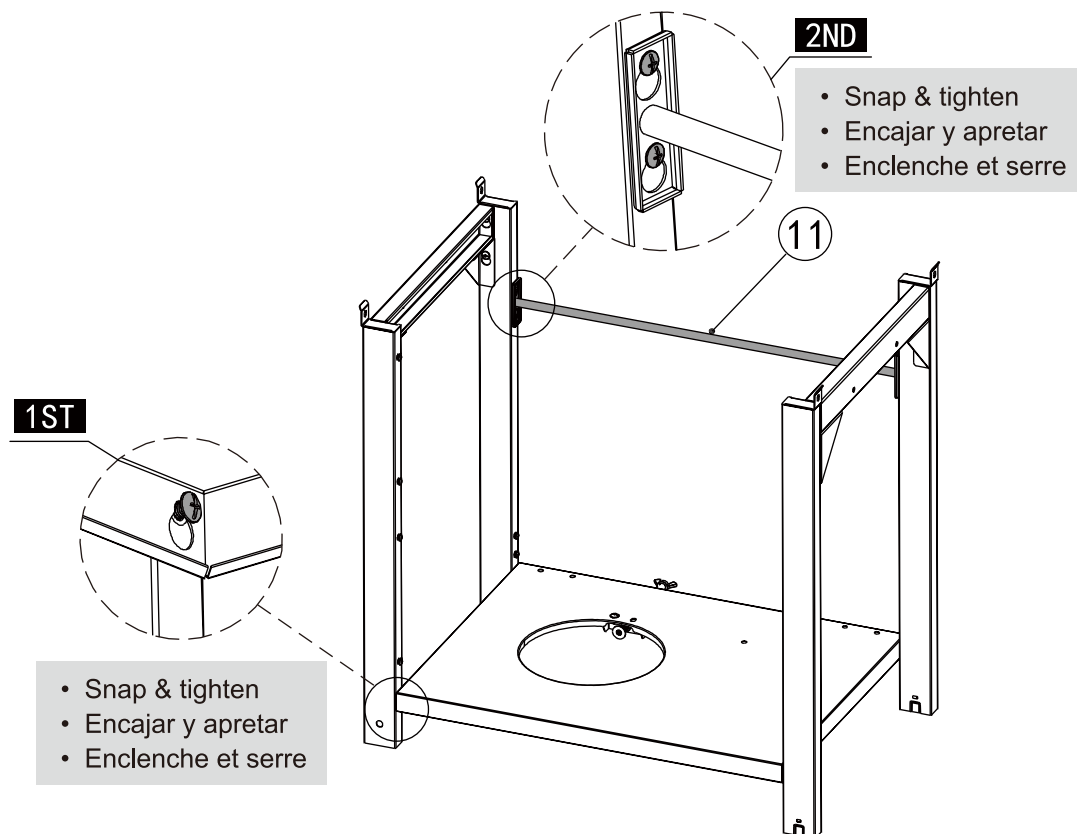

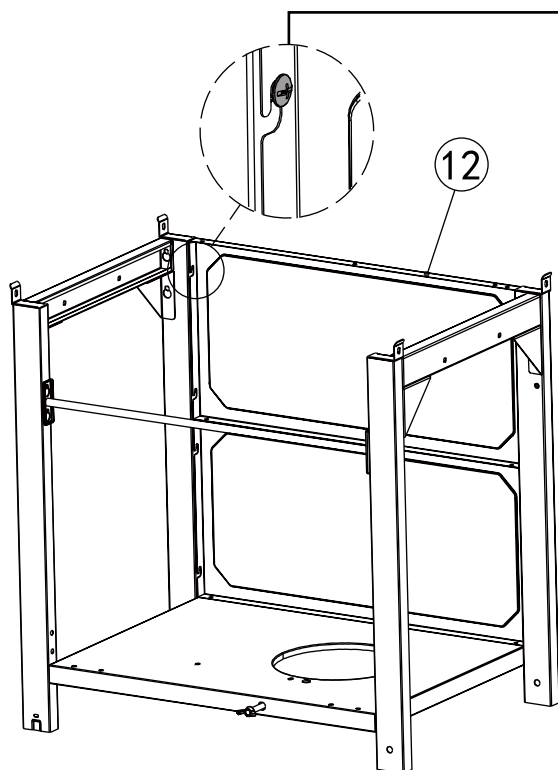

7



- Snap & tighten
- Encajar y apretar
- Enclenche et serrez

8

E		×2
F		×2

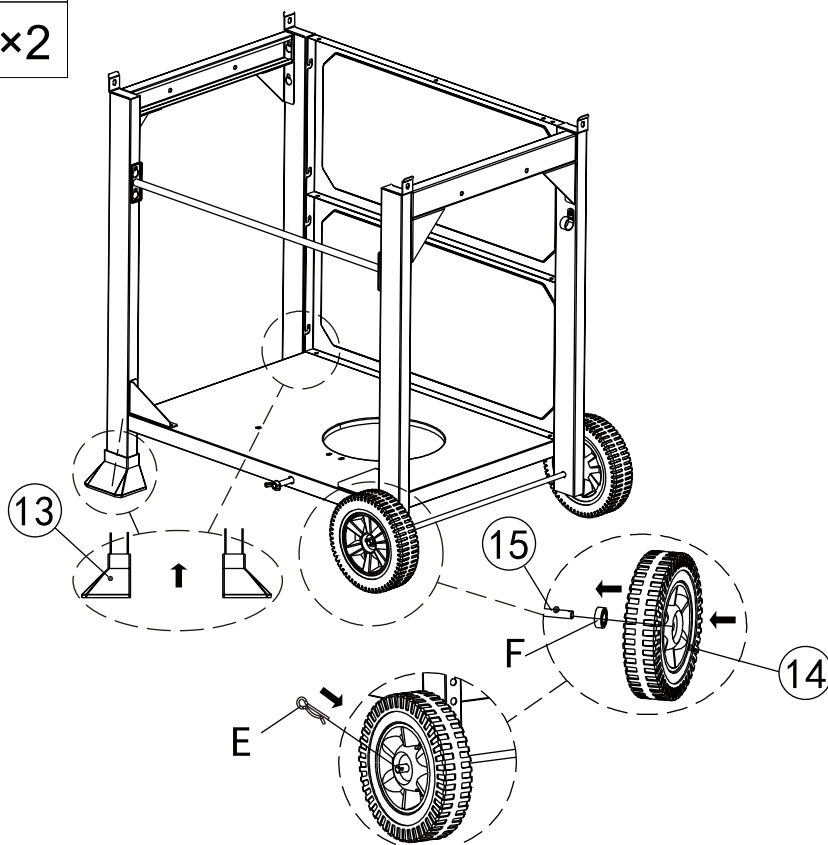

9 B  ×2

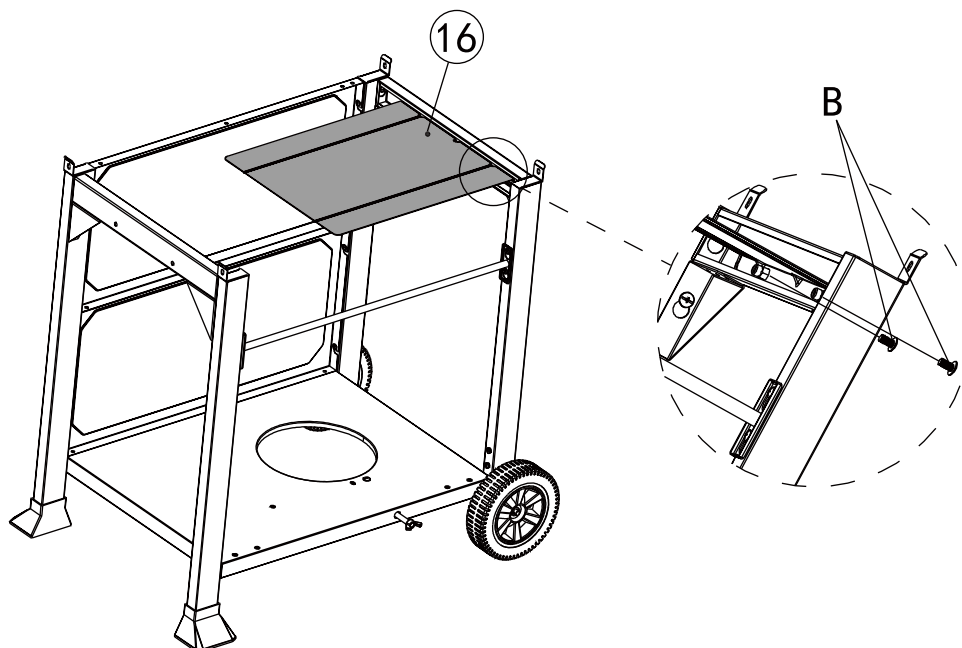

10 A  ×1

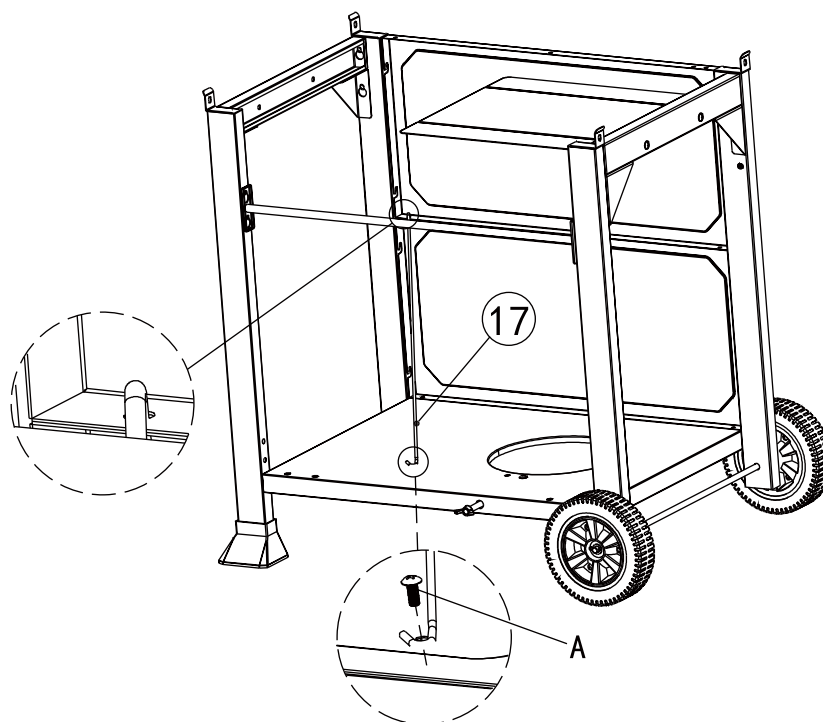

11 B  ×8

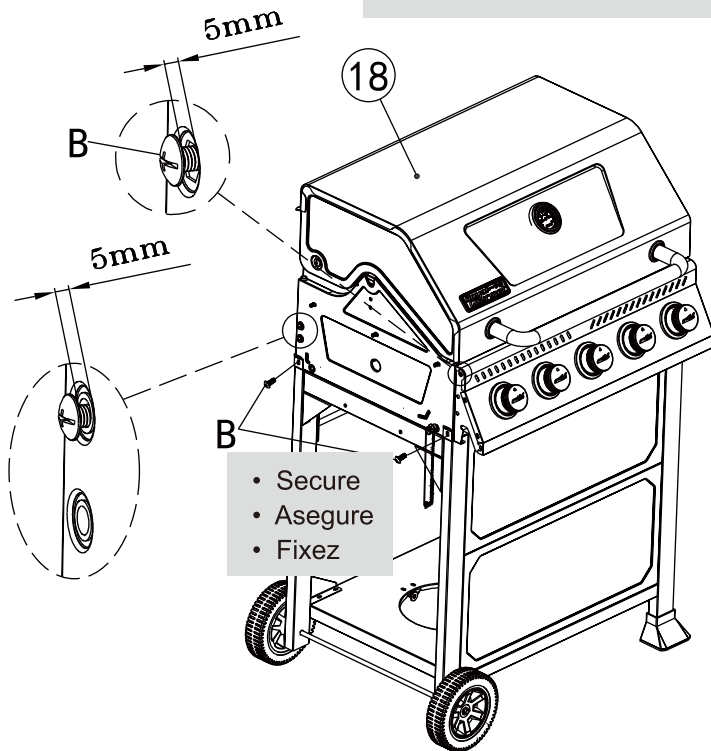

- Release the ignitor and regulator in advance.
- Libere el encendedor y regulador por adelantado.
- Déverrouillez l'allumeur et le régulateur à l'avance.



- Secure
- Asegure
- Fixez



- Repeat for the other side.
- Repita esto paso para el otro lado.
- Répéter le étape pour l'autre côté.

12 G  ×1
D  ×1

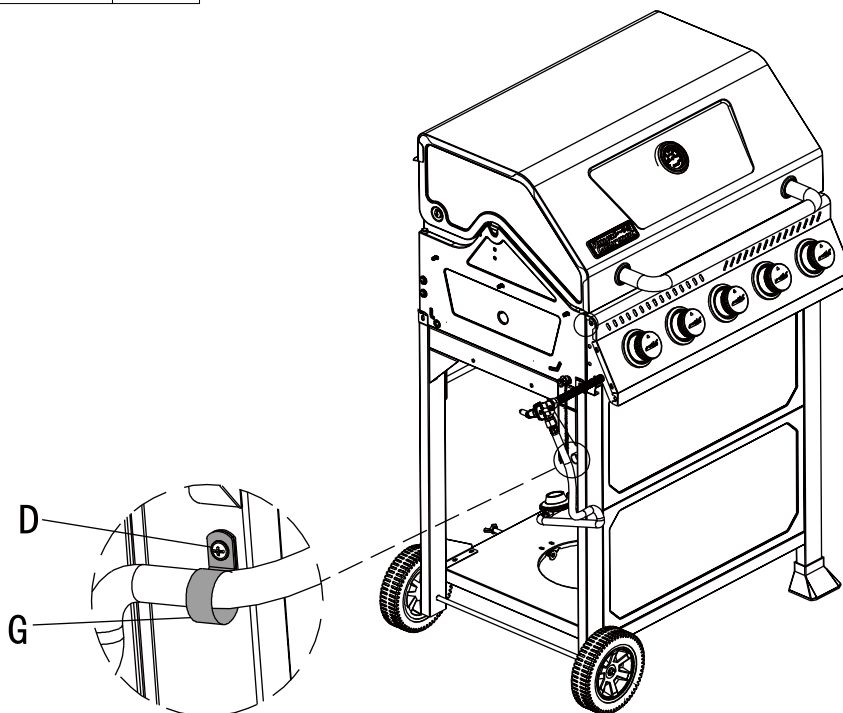

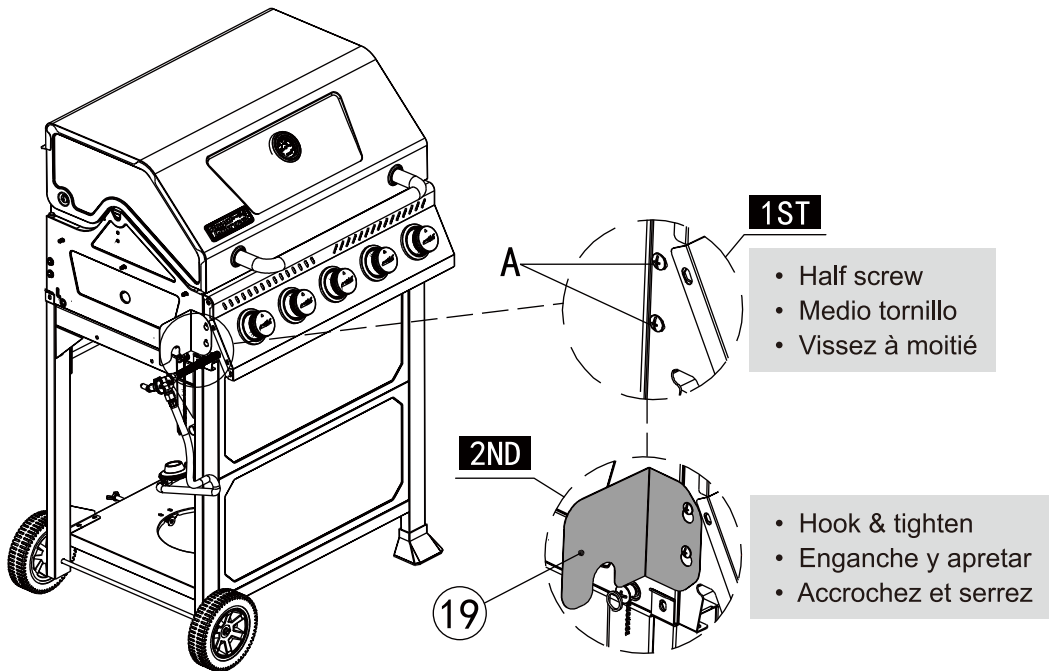

13 A  ×2

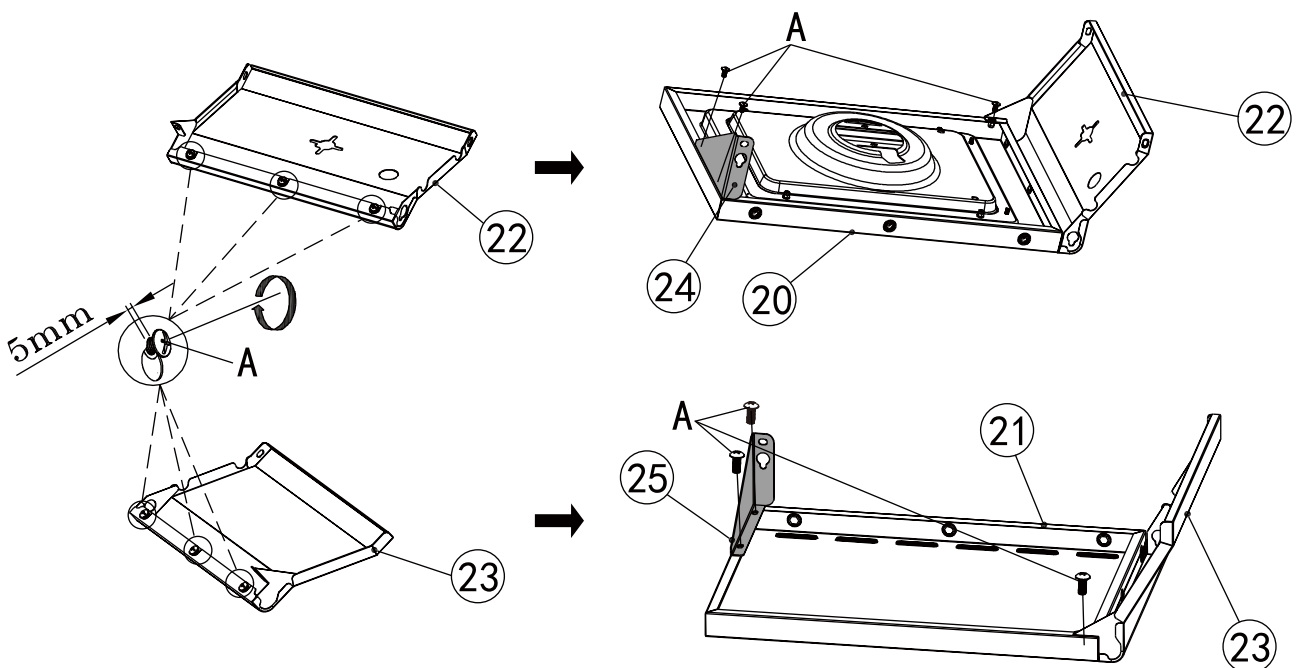

14 A  ×12

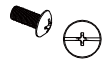
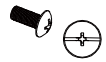

15

A		×2
B		×8
H		×6

1ST

- Hook side tables to half-screwed bolts, then tighten.
- Engancha las mesas auxiliares a los pernos medio atornillados.
- Accrochez des tables d'appoint à des boulons à moitié dévissés.

2ND

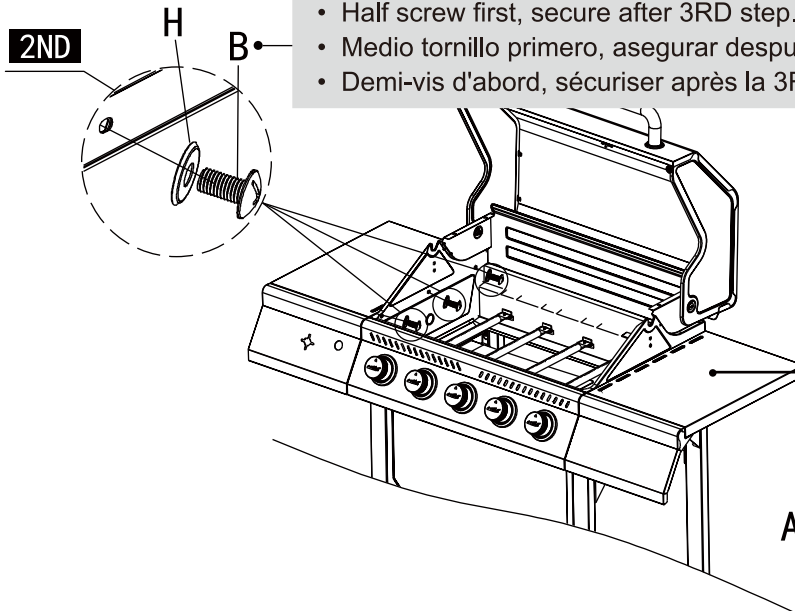

- Half screw first, secure after 3RD step.
- Medio tornillo primero, asegurar después del 3RD paso.
- Demi-vis d'abord, sécuriser après la 3RD étape.

3RD

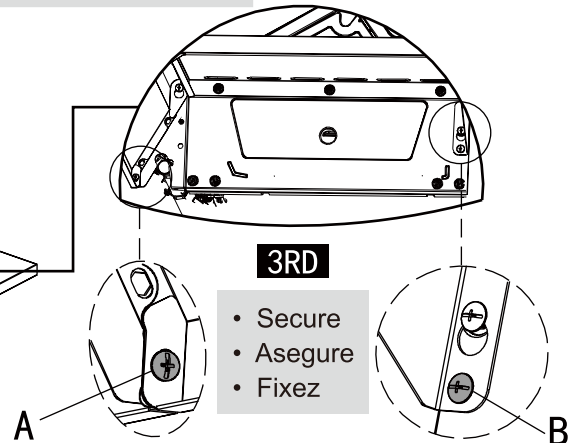

- Secure
- Asegure
- Fixez

16

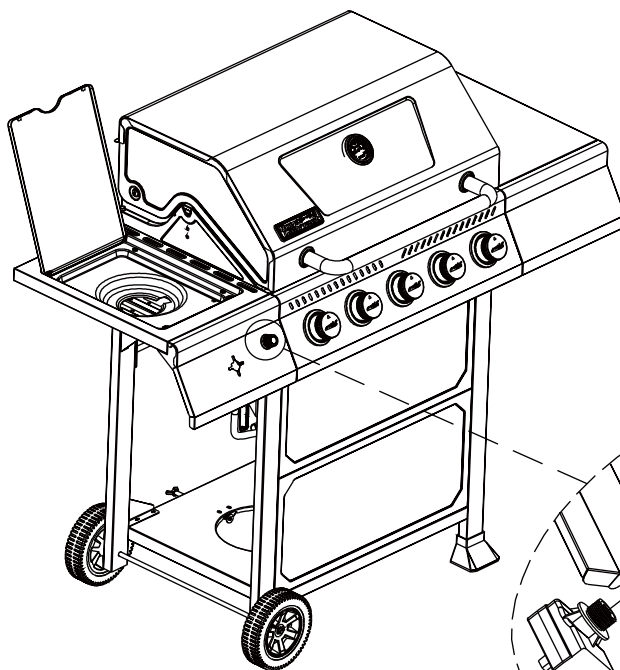

- AA battery not included.
- Pila AA no incluida.
- Pile AA non incluse.

17 C  ×2

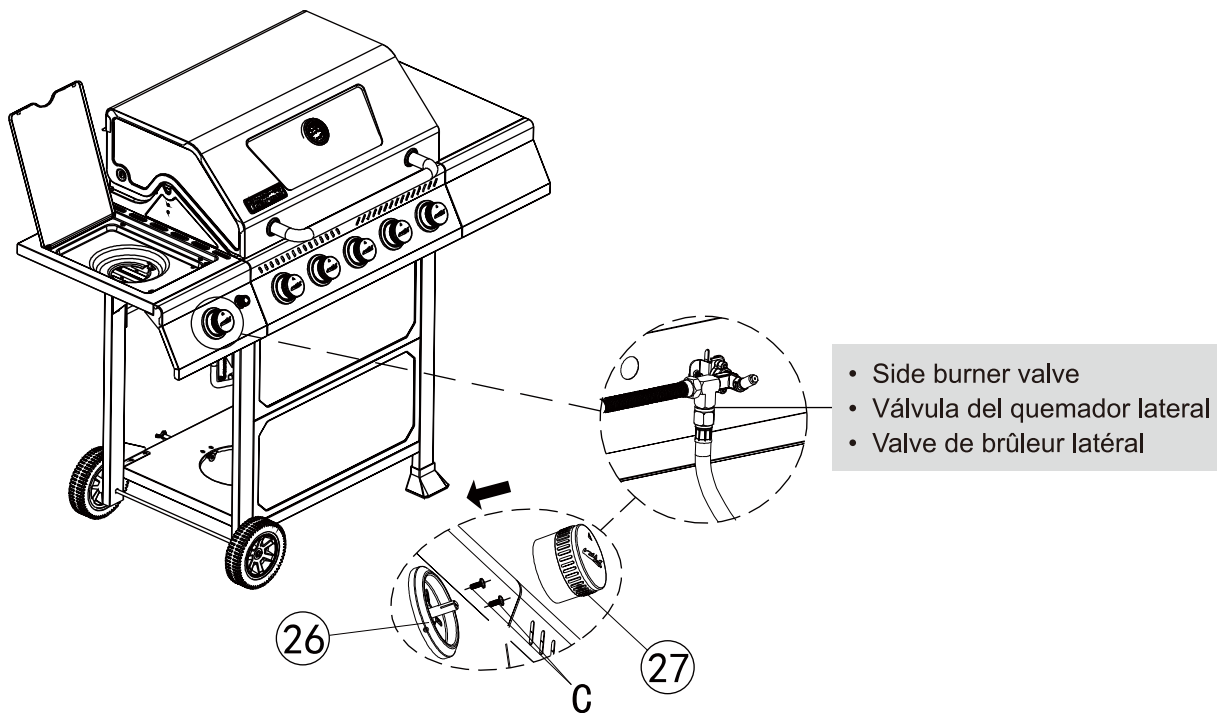

18 C  ×2

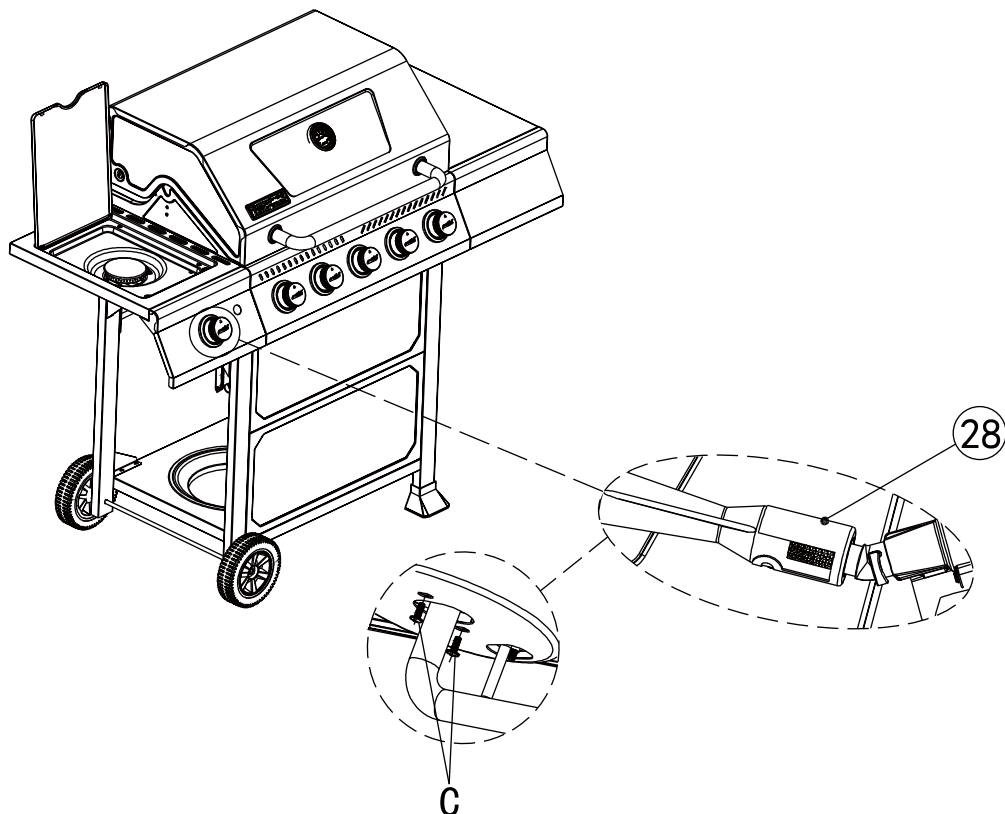

19

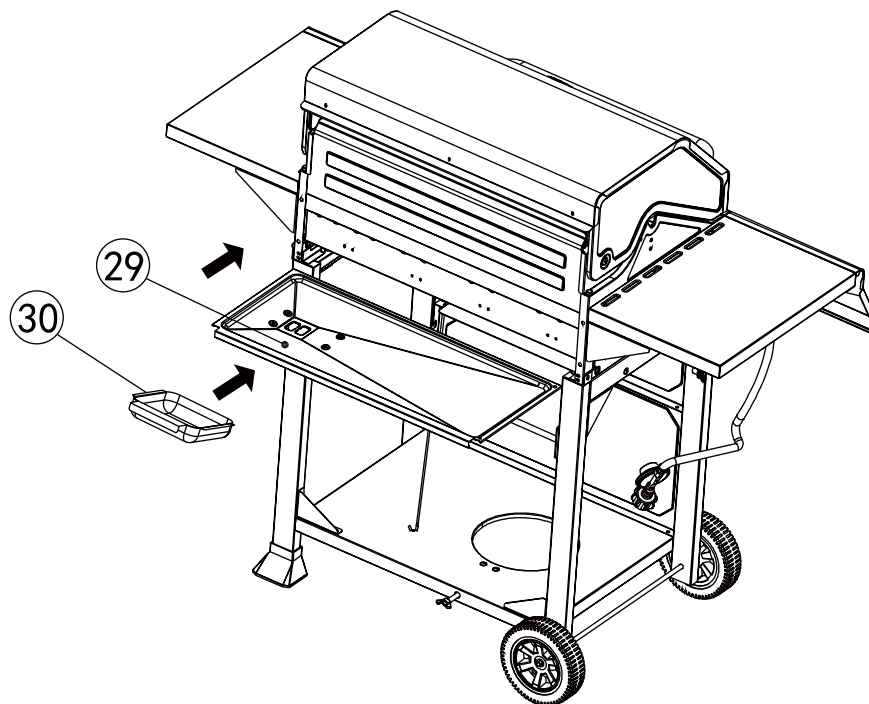

20

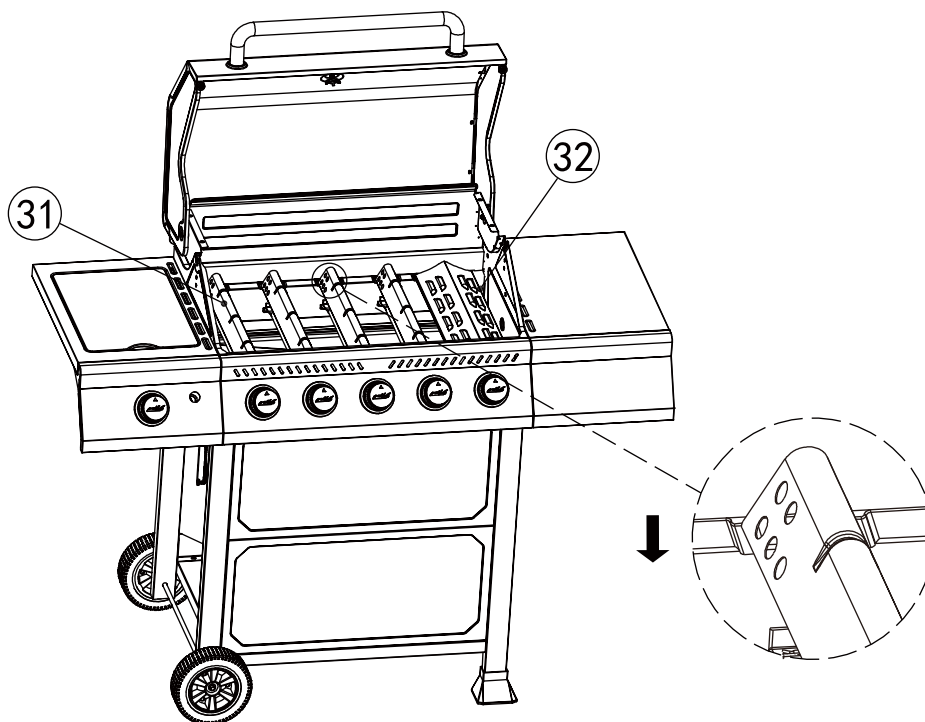

21

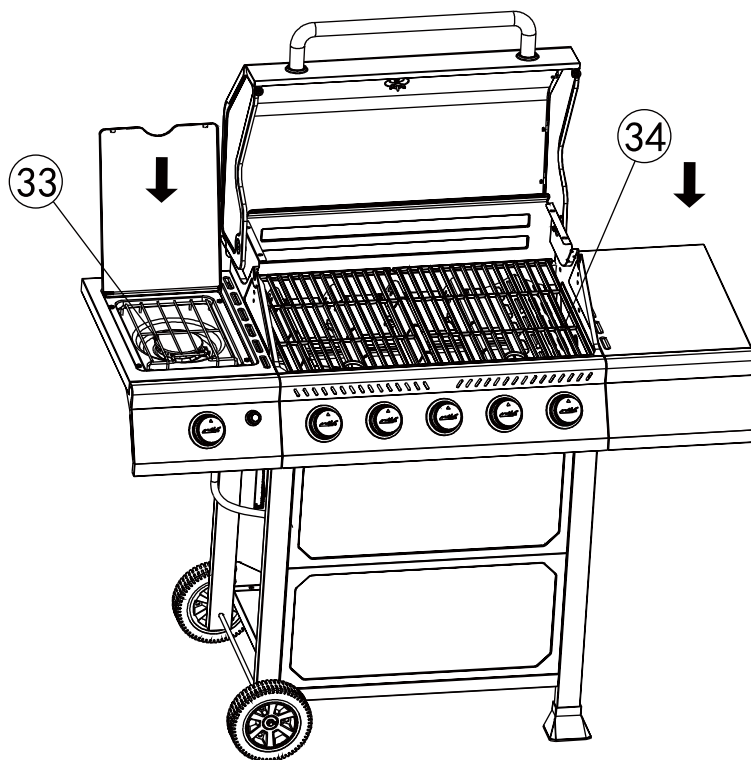

22

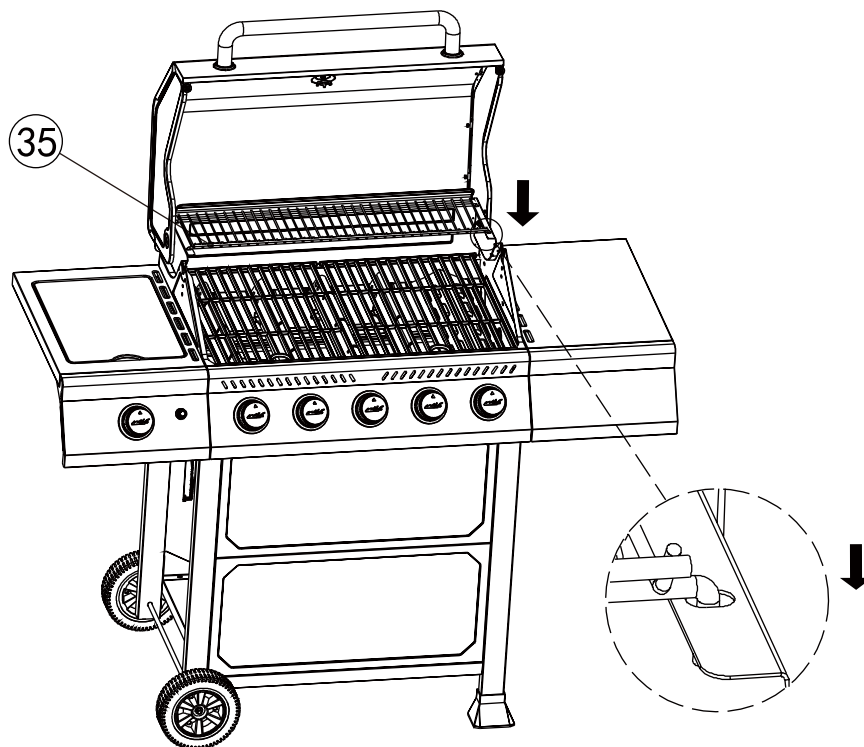

23

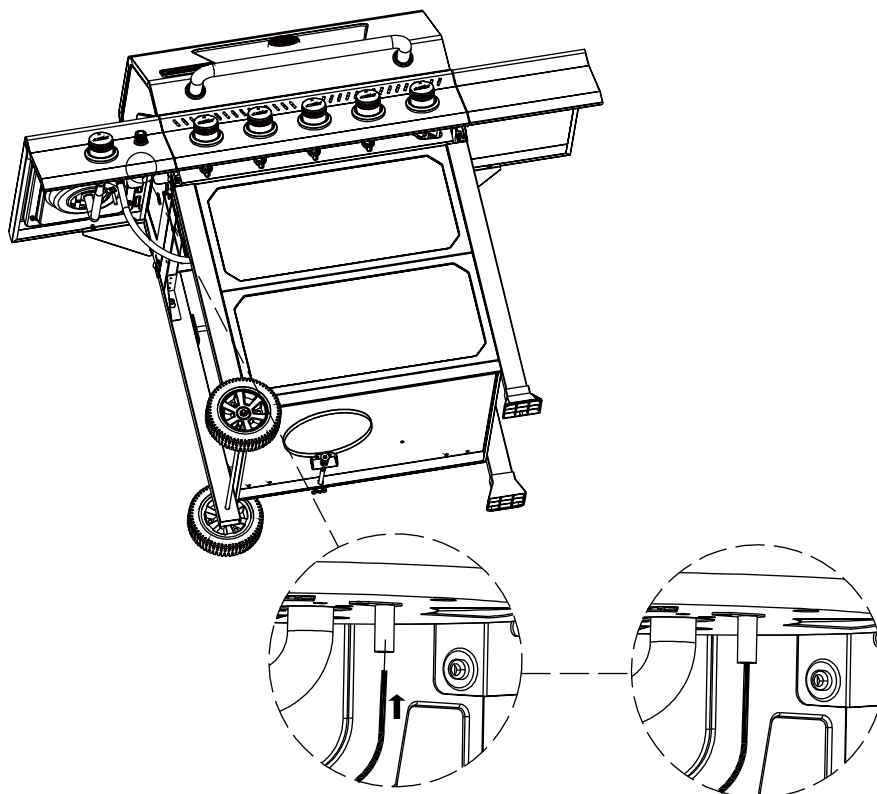

24

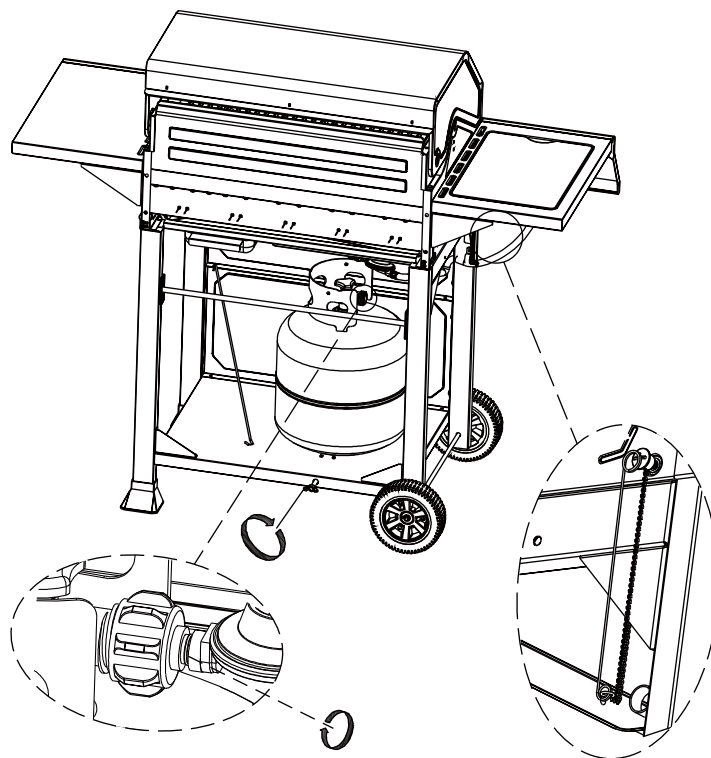

**Thank You
For Choosing Us.**

**Any Problem!
We Can Help!**

**Customer
Service**

1-800-618-6798

Monday to Friday (8:30 am - 5:30 pm EST)

service@royalgourmetusa.com